

4

3

2

1

F

F

E

E

D

D

C

C

B

B

A

A

1030

A

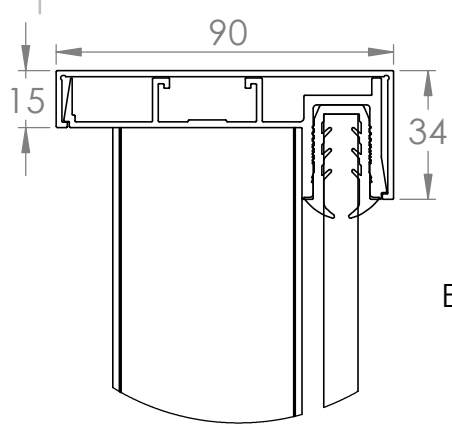

DÉTAIL A
ECHELLE 1 : 2

Verre 44.2

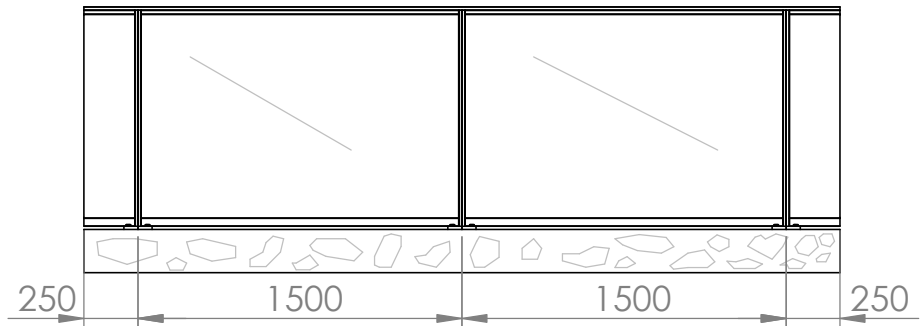

DÉTAIL B
ECHELLE 1 : 2

DÉTAIL DES PLATINES

B

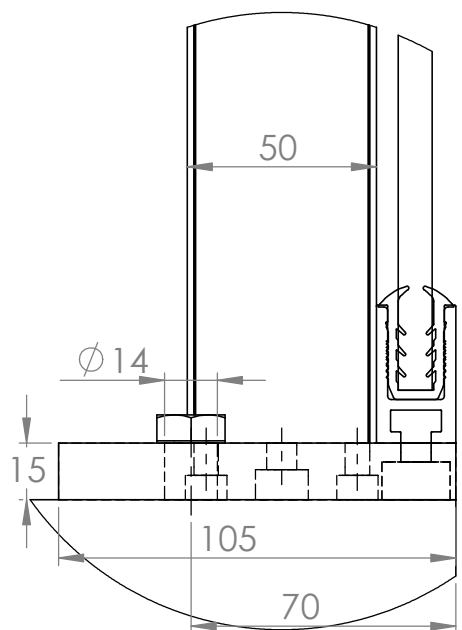

(Cote entre bord de maçonnerie et fixation de platine)

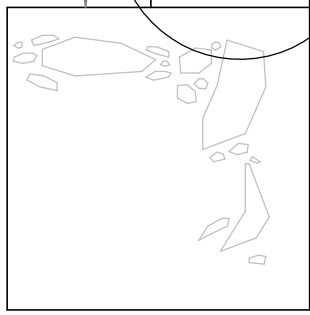
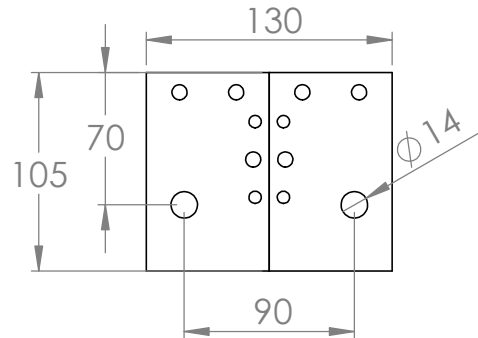
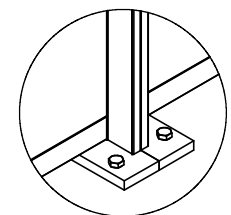

Goujons d'ancrages non fournis, mais doivent être obligatoirement en inox

Modèle **KLAIR**
MAJUSKULE
GARDE-CORPS

LES CÔTES SONT EN mm

4

3

2

1